

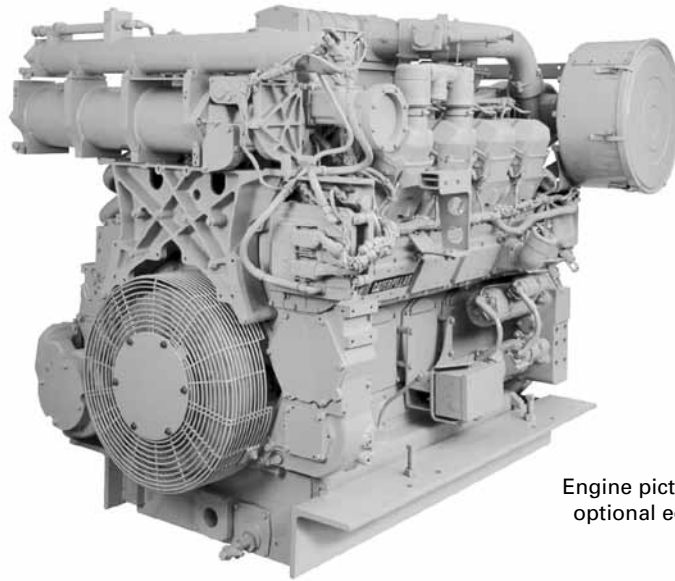

Locomotive Engine
820-970 bkW
1100-1300 bhp

3508B



Engine pictured with optional equipment

CAT® ENGINE SPECIFICATIONS

8-Cylinder, Four-Stroke-Cycle Diesel

Bore 170 mm (6.7 in)
Stroke 190 mm (7.5 in)
Displacement 34.5 L (2105 in³)
Aspiration Turbocharged-Aftercooled
Rotation (from flywheel end) Counterclockwise
Capacity for Liquids
Cooling System 103 L (27 U.S. gal)
Lube Oil System (refill) 224 L (59 U.S. gal)

Weight, Net Dry (approx)

Including flywheel 4355 kg (9600 lb)
Cold Start Capability 10°C (50°F)
Compression Ratio 14.1
Electronic Fuel Injection .. Meets current EPA/ERRI exhaust emissions levels

ENGINE DIMENSIONS

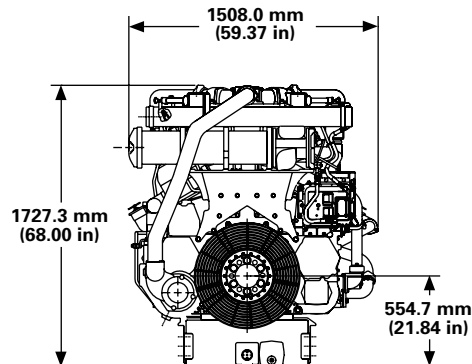
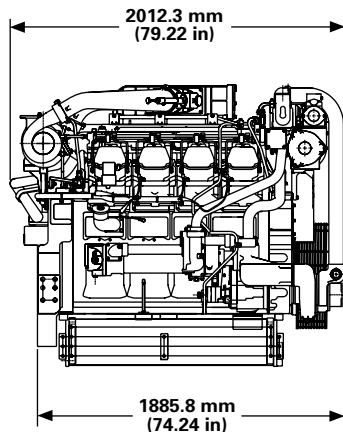



Locomotive Engine

3508B

820-970 bkW 1100-1300 bhp

FACTORY INSTALLED STANDARD AND OPTIONAL EQUIPMENT

SYSTEM	STANDARD EQUIPMENT	OPTIONAL EQUIPMENT
Air Inlet	Aftercooler core, material: copper nickel Two rear-mounted turbochargers	Air cleaners — single or dual element Air inlet adapters for air cleaners
Control System	ADEM™ control, electronic engine control, requires isolated 10 amps at 24 volts DC for operation	Customer Control Module (CCM) (shipped loose) provides interface between engine control and customer control Throttle position signal conversion module (shipped loose) — provides PWM signal to engine control Instrument panel for remote mounting
Cooling System	Thermostats and housing. Full open temperature 92°C (198°F) for engine jacket water Jacket water and separate circuit pumps, gear driven, centrifugal Separate Circuit Aftercooler (SCAC) cooling circuit contains a thermostat to maintain the aftercooler water temperature. Requires customer-supplied cooling system to supply 50°C (122°F) water to achieve maximum performance Connections: jacket water — single inlet, dual outlet, hose type; separate circuit — flange type with companion flange	Jacket water conversion — converts standard separate circuit aftercooled engine to jacket water aftercooling Jacket water connections — flange connections for cooling water inlet and outlet Connections (shipped loose) — flexible hose and mechanical connections for cooling water
Exhaust System	Exhaust manifold, dry, gas-tight	Exhaust fittings — flexible connections, flanges, and elbows (shipped loose) Exhaust port thermocouples Heat shields
Flywheels and Flywheel Housings	Flywheel, SAE No. 00, 183 teeth Flywheel housing, SAE No. 00 SAE standard rotation	Flywheel and housing SAE No. 0 Flywheel SAE No. 0
Front Housing	Two-sided front housing	
Fuel System	Fuel filters, cartridge type, RH service Fuel transfer pump Electronically controlled unit injectors	Fuel priming pumps (manual) Flexible fuel lines (shipped loose) Hard fuel return line includes flexible hose connections Primary fuel filter (shipped loose) Water/fuel separator (shipped loose) Fuel filter with left-side service Fuel cooler (shipped loose)
Lube System	Crankcase breathers, top mounted, 51 mm (2 in) OD outlet Oil cooler Oil filler, RH, with chained stopper LH and RH dipstick Oil filter, RH Oil pump, gear type Shallow oil pan	Oil pan accessories: oil pan capacities, oil pan drain cover, filler, sampling and drain valve Oil filter with left-side service Fumes disposal (shipped loose) — provides hard fumes disposal tube and flexible hose to route fumes out of the engine compartment Lubricating oil
Power Take-Offs	Accessory driven, lower LH, used to drive SCAC pump	Front accessory drives Auxiliary drive shafts and pulleys Front stub shafts and pulleys
Protection System	Safety shutoff protection, electrical, energized to shutoff Air shutoff, hydraulic actuation, ADEM control Protection override	Remote air shutoff control Programmable relay control — provides control of 7 relays and 6 alarm fault LEDs for customer use Explosion relief valves
Mounting System		Rails (ledge type)
Starting System		Electric starting motors (dual) Electric starting motor magnetic switch enclosure Air starter
General	Paint — Caterpillar yellow Vibration damper and guard Lifting eyes	
Special Locomotive Equipment	Electrical interface Remote junction box provides normal and emergency shutoff Customer connection to ADEM control including: throttle, speed signal, general alarm relay (NC or NO contacts) (GAR), shutdown notify relay (NC or NO contacts) (SDNR), start enable relay (NC or NO contacts) (SER), Cat data link, load feedback, torque limiting, remote emergency and normal shutdown switch connections, engine electrical power connections	



Locomotive Engine

3508B

820-970 bkW
1100-1300 bhp

PERFORMANCE CURVES AND DATA

Separate Circuit Aftercooled (SCAC)*

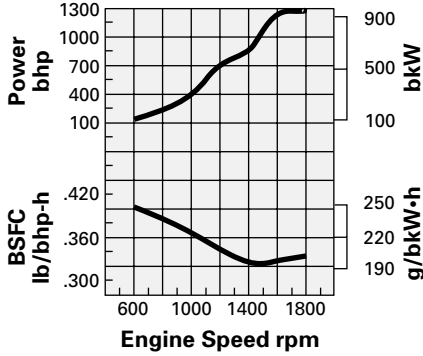

DM4425

Rated bkW (bhp) flywheel	970 (1300)
Full Load — rpm	1800
Low Idle — rpm	600
Operating Range — rpm	600-1800
Altitude Capability — m (ft)	
max operating altitude	800 (2,625)
Fuel Consumption — L/hr (gal/hr)	
Idle (600 rpm)	6.8 (1.8)
Full Load (1800 rpm)	236.0 (62.3)
BSFC — g/bkW-hr (lb/bhp-hr)	
Full Load (1800 rpm)	197.6 (.325)

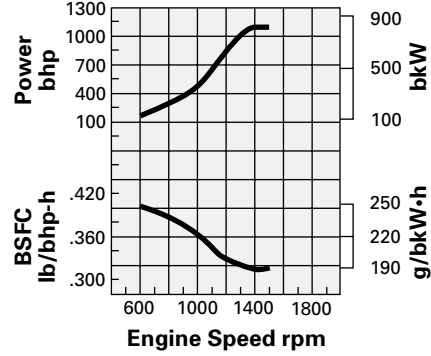

DM4428

Rated bkW (bhp) flywheel	820 (1100)
Full Load — rpm	1500
Low Idle — rpm	600
Operating Range — rpm	600-1500
Altitude Capability — m (ft)	
max operating altitude	800 (2,625)
Fuel Consumption — L/hr (gal/hr)	
Idle (600 rpm)	6.8 (1.8)
Full Load (1800 rpm)	188.4 (49.8)
BSFC — g/bkW-hr (lb/bhp-hr)	
Full Load (1800 rpm)	191.6 (.315)

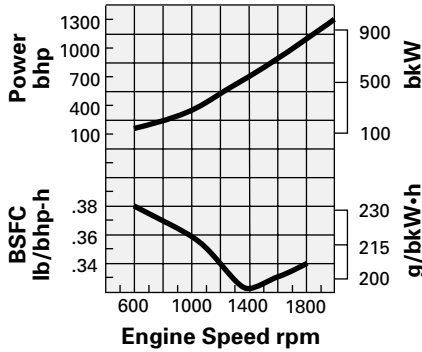

DM6810-01

Rated bkW (bhp) flywheel	970 (1300)
Full Load — rpm	1800
Low Idle — rpm	600
Operating Range — rpm	600-1800
Altitude Capability — m (ft)	
max operating altitude	800 (2,625)
Fuel Consumption — L/hr (gal/hr)	
Idle (600 rpm)	6.8 (1.8)
Full Load (1800 rpm)	241.0 (63.1)
BSFC — g/bkW-hr (lb/bhp-hr)	
Full Load (1400 rpm)	197.5 (.320)

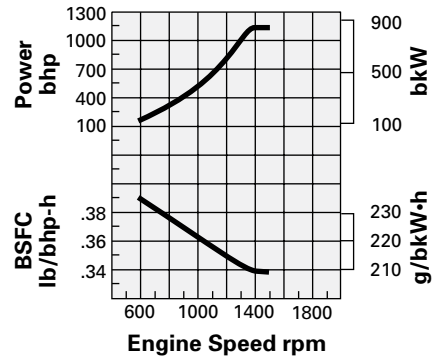

DM6997-00

Rated bkW (bhp) flywheel	820 (1100)
Full Load — rpm	1500
Low Idle — rpm	600
Operating Range — rpm	600-1500
Altitude Capability — m (ft)	
max operating altitude	800 (2,625)
Fuel Consumption — L/hr (gal/hr)	
Idle (600 rpm)	6.8 (1.8)
Full Load (1800 rpm)	202.4 (53.4)
BSFC — g/bkW-hr (lb/bhp-hr)	
Full Load (1300 rpm)	204.1 (.340)

*SCAC performance data is based on 55°C (131°F) cooling water.



Locomotive Engine

3508B

820-970 bkW 1100-1300 bhp

PERFORMANCE CURVES AND DATA

Jacket Water Aftercooled (JWAC)**

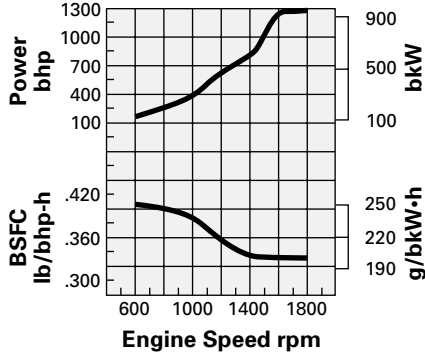

DM4427

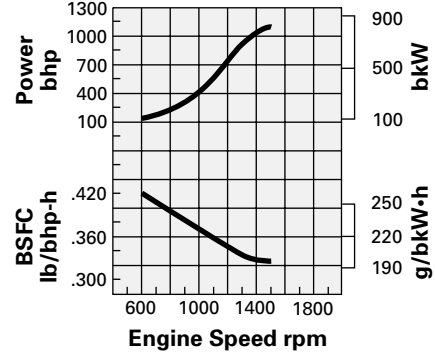

DM4430

Rated bkW (bhp) flywheel	970 (1300)
Full Load — rpm	1800
Low Idle — rpm	600
Operating Range — rpm	600-1800
Altitude Capability — m (ft)	
max operating altitude	800 (2,625)
Fuel Consumption — L/hr (gal/hr)	
Idle (600 rpm)	6.8 (1.8)
Full Load (1800 rpm)	236.2 (62.4)
BSFC — g/bkW-hr (lb/bhp-hr)	
Full Load (1800 rpm)	201.0 (.330)

Rated bkW (bhp) flywheel	820 (1100)
Full Load — rpm	1500
Low Idle — rpm	600
Operating Range — rpm	600-1500
Altitude Capability — m (ft)	
max operating altitude	800 (2,625)
Fuel Consumption — L/hr (gal/hr)	
Idle (600 rpm)	6.8 (1.8)
Full Load (1800 rpm)	194.1 (51.3)
BSFC — g/bkW-hr (lb/bhp-hr)	
Full Load (1800 rpm)	197.6 (.325)

**JWAC performance data is based on 90°C (194°F) cooling water to engine pump.

RATINGS DEFINITIONS AND CONDITIONS

Performance obtained and corrected in accordance with ISO3046/2 standard atmospheric conditions of 99 kPa (29.31 in Hg) and 25° C (77° F). These values correspond to the standard atmospheric pressure and temperature as shown on SAE J1995.

Performance and fuel consumption are based on 35 API 15° C (60° F) gravity fuel having an LHV of 42 780 kJ/kg (18,390 Btu/lb) when used at 29° C (85° F) where the density is 839.9 g/liter (7.001 lb/U.S. gal). Tolerance is +/- 3%.

Engine equipped with fuel, lube oil, and water pumps.

Materials and specifications are subject to change without notice. The International System of Units (SI) is used in this publication. CAT, CATERPILLAR, their respective logos, ADEM, "Caterpillar Yellow" and the "Power Edge" trade dress, as well as corporate and product identity used herein, are trademarks of Caterpillar and may not be used without permission.