

Shown with
Optional Equipment

CAT® ENGINE SPECIFICATIONS

V-16, 4-Stroke-Cycle

Bore	170 mm (6.7 in.)
Stroke	190 mm (7.5 in.)
Displacement	69 L (4210 cu. in.)
Aspiration	Turbocharged-Aftercooled
Digital Engine Management	
Governor and Protection	Electronic (ADEM™ A3)
Combustion	Low Emission (Lean Burn)
Engine Weight, net dry (approx)	8015 kg (17,670 lb)
Power Density	8 kg/kW (13.2 lb/bhp)
Power per Displacement	19.3 bhp/L
Total Cooling System Capacity	217.7 L (57.5 gal)
Jacket Water	200.6 L (53 gal)
Aftercooler Circuit	17 L (4.5 gal)
Lube Oil System (refill)	424 L (112 gal)
Oil Change Interval	1000 hours
Rotation (from flywheel end)	Counterclockwise
Flywheel and Flywheel Housing	SAE No. 00
Flywheel Teeth	183

FEATURES

Engine Design

- Proven reliability and durability
- Ability to burn a wide spectrum of gaseous fuels
- Robust diesel strength design prolongs life and lowers owning and operating costs
- Broad operating speed range

Emissions

Meets U.S. EPA Spark Ignited Stationary NSPS Emissions for 2007/8

Lean Burn Engine Technology

Lean-burn engines operate with large amounts of excess air. The excess air absorbs heat during combustion reducing the combustion temperature and pressure, greatly reducing levels of NOx. Lean-burn design also provides longer component life and excellent fuel consumption.

Advanced Digital Engine Management

ADEM A3 control system providing integrated ignition, speed governing, protection, and controls, including detonation-sensitive variable ignition timing. ADEM A3 has improved: user interface, display system, shutdown controls, and system diagnostics.

Ease of Operation

Side covers on block allow for inspection of internal components

Full Range of Attachments

Large variety of factory-installed engine attachments reduces packaging time

Testing

Every engine is full-load tested to ensure proper engine performance.

Gas Engine Rating Pro

GERP is a PC-based program designed to provide site performance capabilities for Cat® natural gas engines for the gas compression industry. GERP provides engine data for your site's altitude, ambient temperature, fuel, engine coolant heat rejection, performance data, installation drawings, spec sheets, and pump curves.

Product Support Offered Through Global Cat Dealer Network

More than 2,200 dealer outlets

Cat factory-trained dealer technicians service every aspect of your petroleum engine

Cat parts and labor warranty

Preventive maintenance agreements available for repair-before-failure options

S•O•S™ program matches your oil and coolant samples against Caterpillar set standards to determine:

- Internal engine component condition
- Presence of unwanted fluids
- Presence of combustion by-products
- Site-specific oil change interval

Over 80 Years of Engine Manufacturing Experience

Over 60 years of natural gas engine production

Ownership of these manufacturing processes enables Caterpillar to produce high quality, dependable products.

- Cast engine blocks, heads, cylinder liners, and flywheel housings
- Machine critical components
- Assemble complete engine

Web Site

For all your petroleum power requirements, visit www.catoilandgas.cat.com.

STANDARD EQUIPMENT

Air Inlet System

Air cleaner — intermediate-duty with service indicator

Control System

A3 ECU

Air-fuel ratio control

Cooling System

Thermostats and housing

Jacket water pump

Aftercooler water pump

Aftercooler core for sea-air atmosphere

Aftercooler thermostats and housing

Exhaust System

Watercooled exhaust manifolds

Flywheels & Flywheel Housings

SAE No. 00 flywheel

SAE No. 00 flywheel housing

SAE standard rotation

Fuel System

Gas pressure regulator

Natural gas carburetor

Ignition System

A3 ECU

Instrumentation

PL1000 Advisor panel

Lubrication System

Crankcase breather — top mounted

Oil cooler

Oil filter — RH

Oil bypass filter

Oil pan — shallow

Oil sampling valve

Turbo oil accumulator

Mounting System

Rails, engine mounting — 254 mm (10 in)

Protection System

Electronic shutoff system

Gas shutoff valve

General

Paint — Cat yellow

Vibration damper and guard — dual 484 mm (23 in)

OPTIONAL EQUIPMENT

Air Inlet System

Remote air inlet adapters

Precleaner

Charging System

Battery chargers

Charging alternators

Cooling System

Aftercooler core

Thermostatic valve

Temperature switch

Connections

Expansion and overflow tank

Water level switch gauge

Exhaust System

Flexible fittings

Elbows

Flange

Flange and exhaust expanders

Rain cap

Mufflers

Fuel System

Low pressure gas conversions

Propane gas valve and jet kits

Fuel filter

Instrumentation

PL1000 communications modules

Lubrication System

Oil bypass filter removal and oil pan accessories

Sump pump

Air prelube pump

Manual prelube pump

Lubricating oil

Mounting System

Rails

Vibration isolators

Power Take-Offs

Front accessory drives

Auxiliary drive shafts and pulleys

Front stub shaft

Pulleys

Protection System

Explosion relief valves, status control box interconnect wiring harness

Starting System

Air starting motor

Air pressure regulator

Air silencer

Electric air start controls

Electric starting motors — dual 24-volt

Starting aids

Battery sets (24-volt dry), cables, and rack

General

Flywheel inertia weight

Guard removal

Engine barring group

Premium 8:1 pistons

Premium cylinder heads

TECHNICAL DATA
G3516 LE Gas Petroleum Engine

Fuel System		2 g NOx NTE Rating DM8618-01	2 g NOx NTE Rating DM8620-01
Engine Power			
@ 100% Load	bkW (bhp)	999 (1340)	858 (1150)
@ 75% Load	bkW (bhp)	749 (1004)	643 (862)
Engine Speed		1400	1200
Max Altitude @ Rated Torque and 38°C (100°F)	rpm m (ft)	304.8 (1000)	1219.2 (4000)
Speed Turndown @ Max Altitude, Rated Torque, and 38°C (100°F)	%	25	9.2
SCAC Temperature		54 (130)	54 (130)
Emissions*			
NOx	g/bkW-hr (g/bhp-hr)	2.68 (2)	2.68 (2)
CO	g/bkW-hr (g/bhp-hr)	2.49 (1.86)	2.35 (1.75)
CO ₂	g/bkW-hr (g/bhp-hr)	632 (471)	624 (466)
VOC**	g/bkW-hr (g/bhp-hr)	0.35 (0.26)	0.4 (0.3)
Fuel Consumption***			
@ 100% Load	MJ/bkW-hr (Btu/bhp-hr)	10.48 (7405)	10.36 (7324)
@ 75% Load	MJ/bkW-hr (Btu/bhp-hr)	10.79 (7628)	10.76 (7605)
Heat Balance			
Heat Rejection to Jacket Water			
@ 100% Load	bkW (Btu/mn)	741 (42,123)	639 (36,343)
@ 75% Load	bkW (Btu/mn)	616.7 (35,075)	554 (31,480)
Heat Rejection to Aftercooler			
@ 100% Load	bkW (Btu/mn)	167.8 (9546)	131.9 (7509)
@ 75% Load	bkW (Btu/mn)	108.6 (6179)	72.2 (4108)
Heat Rejection to Exhaust			
@ 100% Load	bkW (Btu/mn)	837.8 (47,643)	694.6 (39,536)
LHV to 25° C (77° F)			
@ 75% Load	bkW (Btu/mn)	630.4 (35,848)	524.1 (29,806)
LHV to 25° C (77° F)			
Exhaust System			
Exhaust Gas Flow Rate			
@ 100% Load	m ³ /min (cfm)	217.0 (7663)	182.9 (6460)
@ 75% Load	m ³ /min (cfm)	163.8 (5785)	138.9 (4905)
Exhaust Stack Temperature			
@ 100% Load	°C (°F)	467.22 (873)	452.2 (846)
@ 75% Load	°C (°F)	467.22 (873)	450.5 (843)
Intake System			
Air Inlet Flow Rate			
@ 100% Load	m ³ /min (scfm)	80.6 (2847)	69.5 (2453)
@ 75% Load	m ³ /min (scfm)	60.8 (2147)	52.8 (1864)
Gas Pressure		241.5-275.8 (35-40)	241.5-275.8 (35-40)

*at 100% load and speed, all values are listed as not to exceed

**Volatile organic compounds as defined in U.S. EPA 40 CFR 60, subpart JJJJ

***ISO 3046/1

GAS PETROLEUM ENGINE

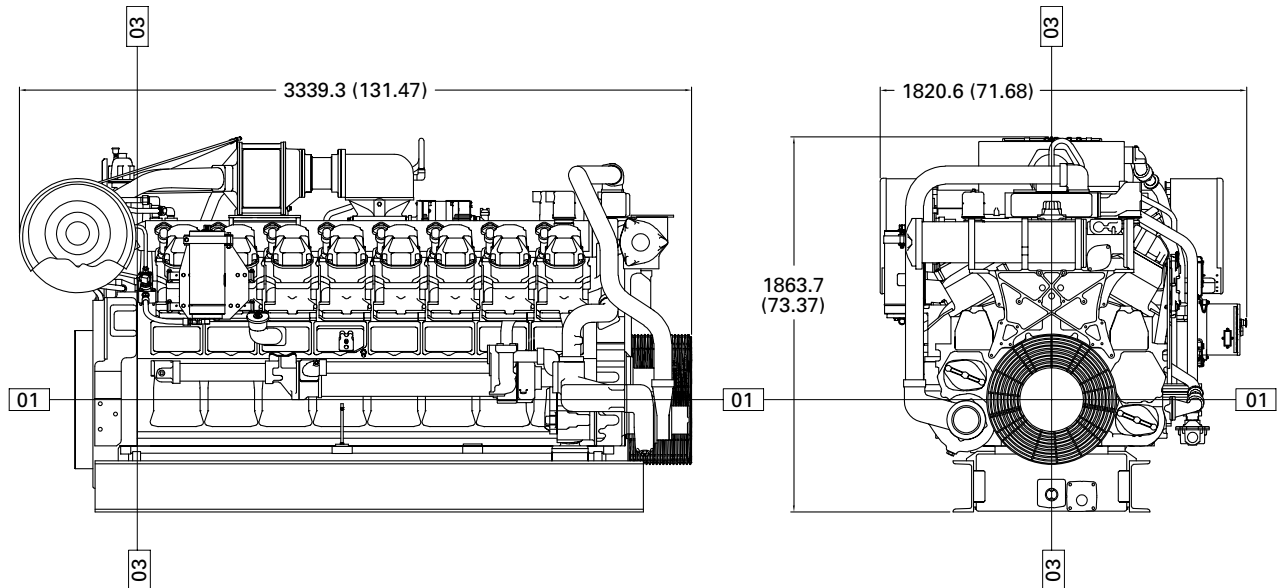

DIMENSIONS		
Length	mm (in.)	3339.3 (131.47)
Width	mm (in.)	1820.6 (71.68)
Height	mm (in.)	1863.7 (73.37)
Shipping Weight	kg (lb)	8015 (17,670)

Note: General configuration not to be used for installation. See general dimension drawings for detail (drawing #289-2971).

Dimensions are in mm (inches).

RATING DEFINITIONS AND CONDITIONS

Engine performance is obtained in accordance with SAE J1995, ISO3046/1, BS5514/1, and DIN6271/1 standards.

Transient response data is acquired from an engine/generator combination at normal operating temperature and in accordance with ISO3046/1 standard ambient conditions. Also in accordance with SAE J1995, BS5514/1, and DIN6271/1 standard reference conditions.

Conditions: Power for gas engines is based on fuel having an LHV of 33.74 kJ/L (905 Btu/cu ft) at 101 kPa (29.91 in. Hg) and 15° C (59° F). Fuel rate is based on a cubic meter at 100 kPa (29.61 in. Hg) and 15.6° C (60.1° F). Air flow is based on a cubic foot at 100 kPa (29.61 in. Hg) and 25° C (77° F). Exhaust flow is based on a cubic foot at 100 kPa (29.61 in. Hg) and stack temperature.

Materials and specifications are subject to change without notice. The International System of Units (SI) is used in this publication. CAT, CATERPILLAR, their respective logos, ADEM, "Caterpillar Yellow" and the "Power Edge" trade dress, as well as corporate and product identity used herein, are trademarks of Caterpillar and may not be used without permission.